

**MINISTRY OF TOURISM
PROMOTION AND STRENGTHENING OF COMPETENCE
VOCATIONAL OCCUPATIONS
FOR TOURISM**

2014.



GASTRO-FORKS

MECHANICAL ENGINEERING SCHOOL OSIJEK

The objectives to be achieved by the implementation of the project

- The implementation of the project increases the Croatian continental cuisine which is one of 10 key tourism products in development strategy until 2020.
- By including non-tourist sector in the development of tourism in continental Croatia increases and encourages innovation and entrepreneurial spirit, and collaborates with other stakeholders in tourism.

Design stages

- Designing products - fork of stainless steel
- Prototype products
- Testing a prototype GASTRO-forks
- Making a series GASTRO-forks stainless steel
- Presentation of the product

Designing a product-sketch contest

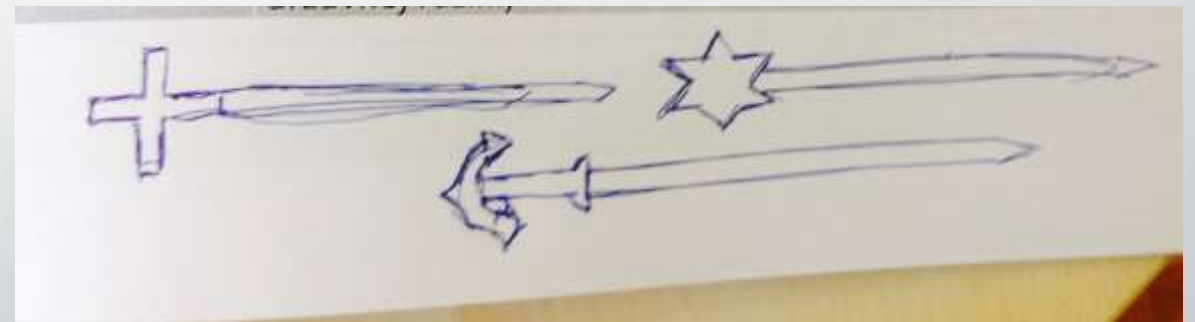
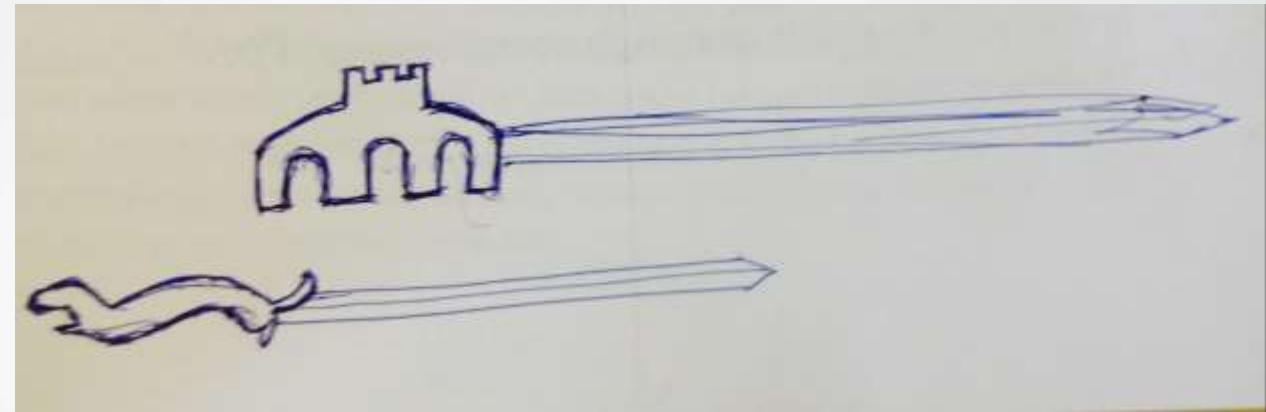
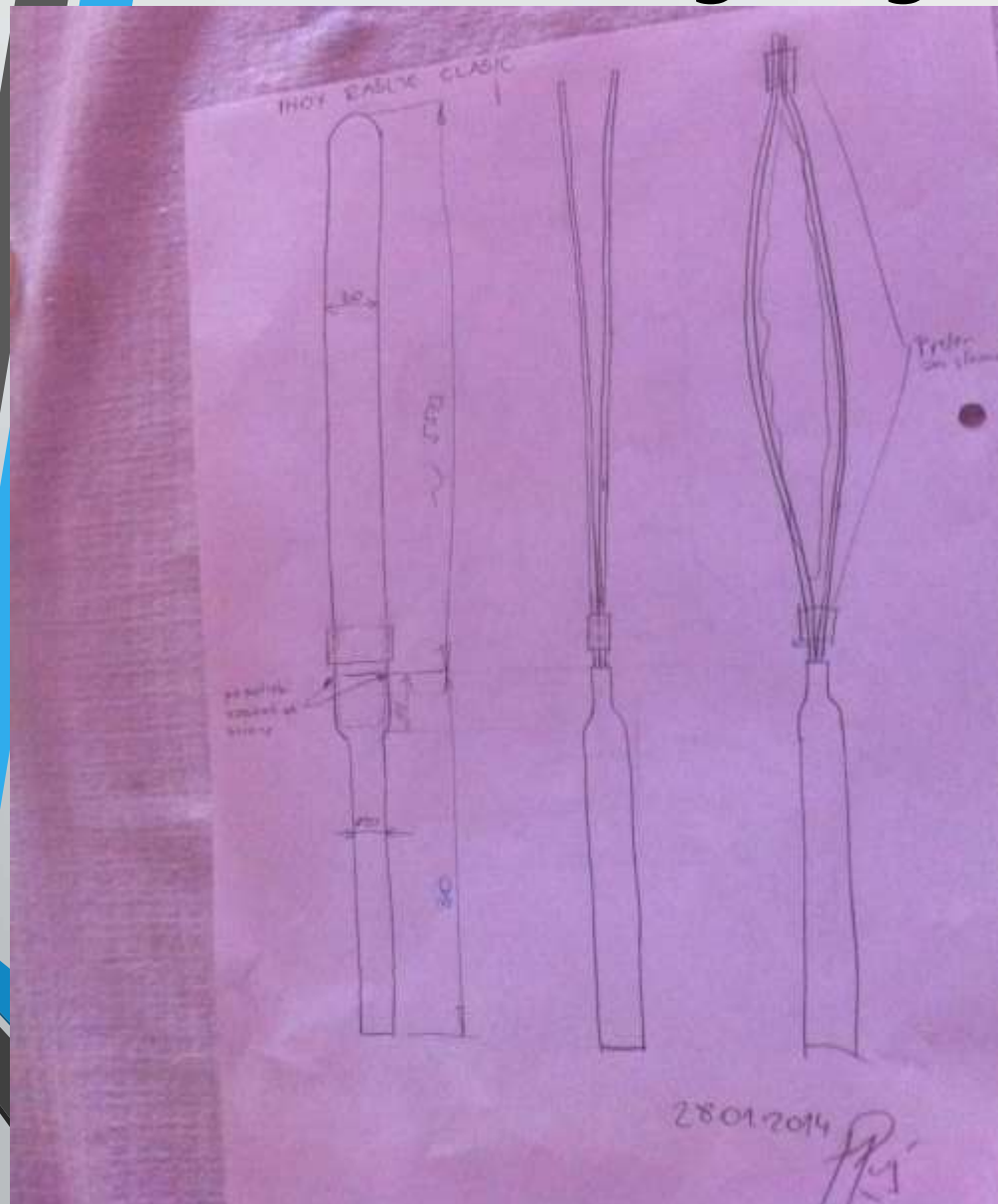

Designing products – CATIA

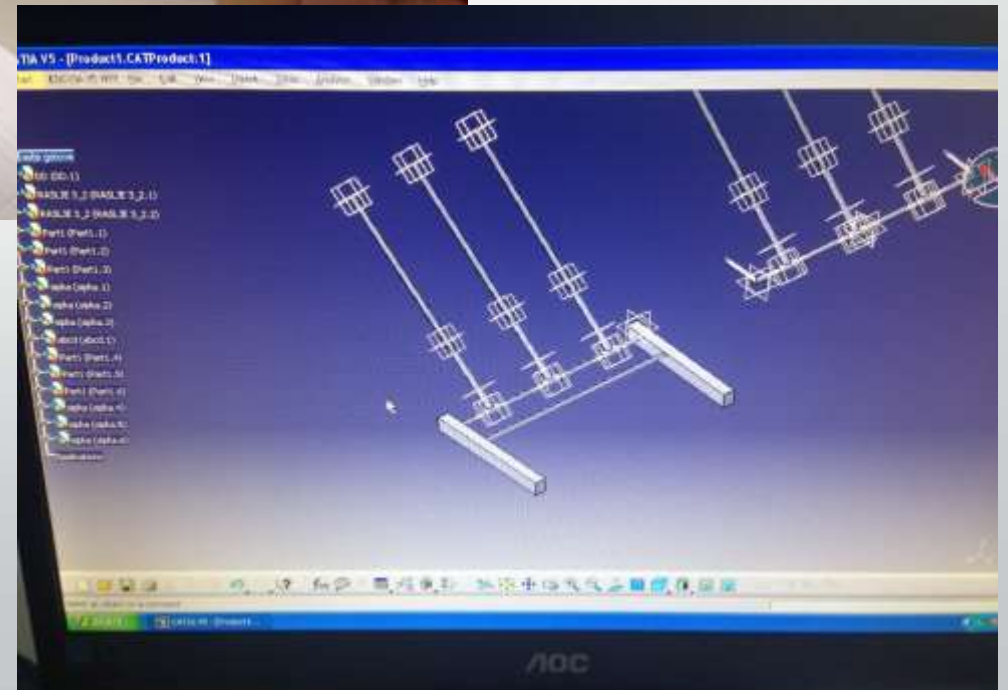
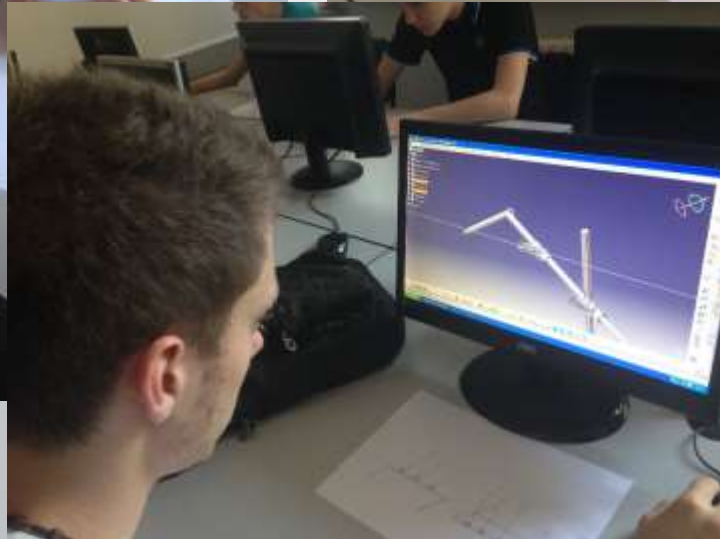
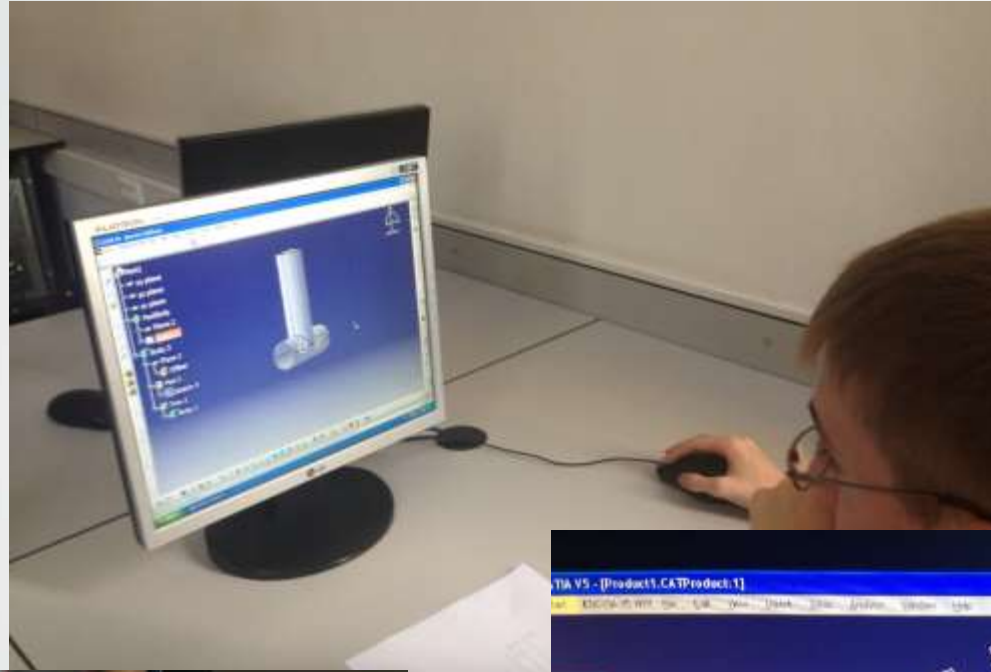
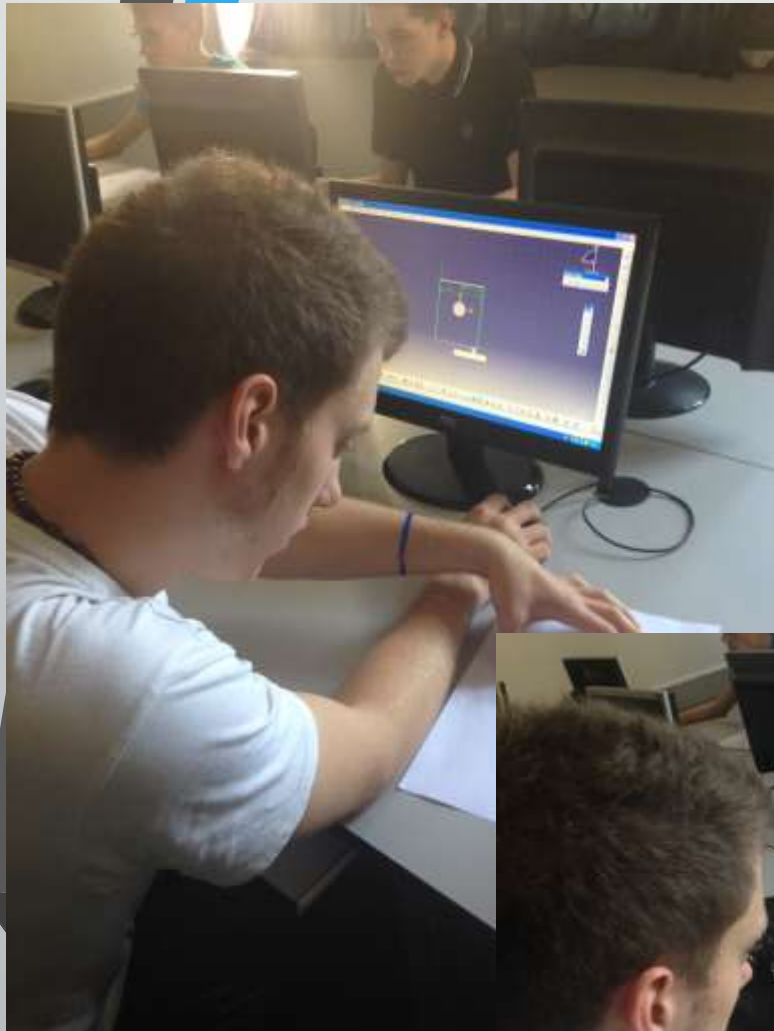

Designing products– CATIA

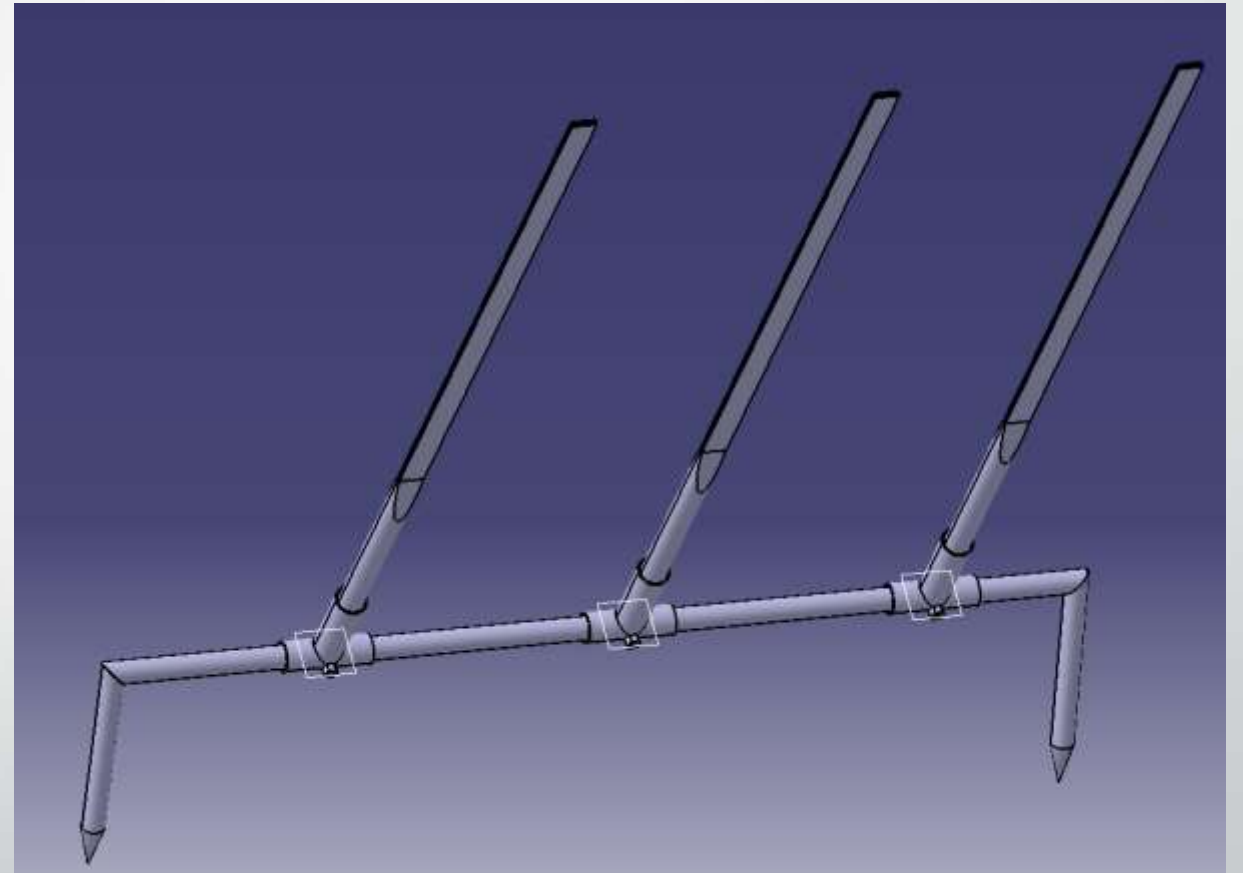
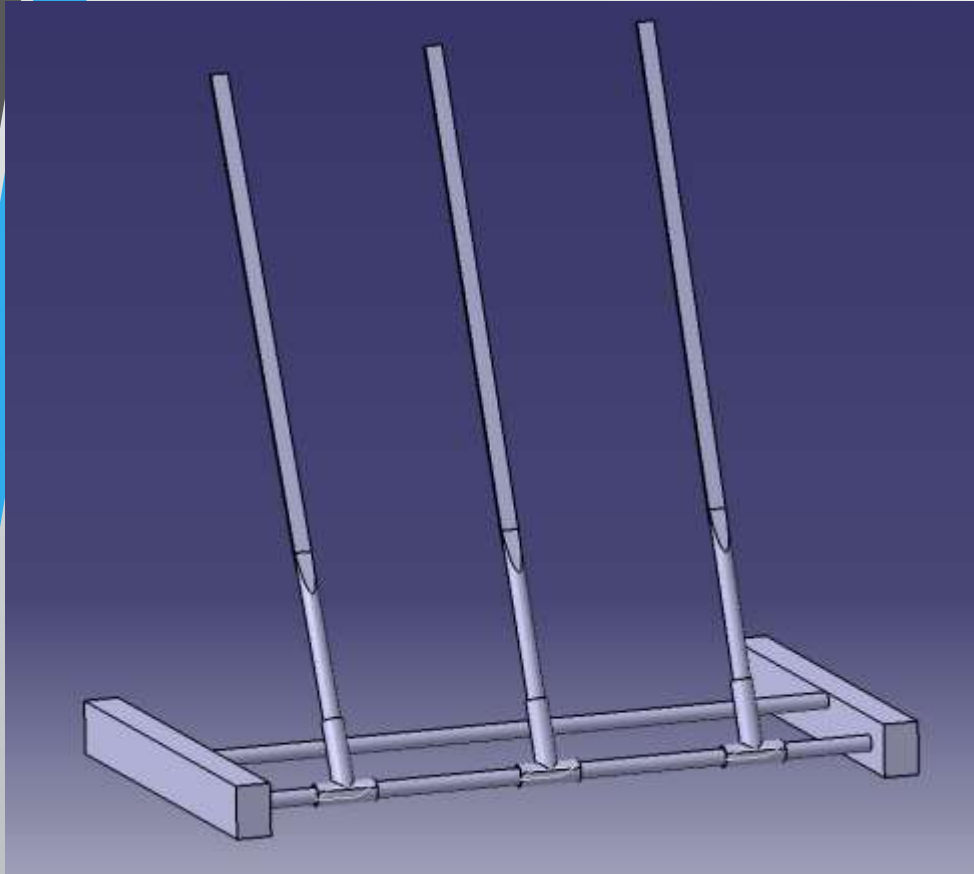

Designing products– AutoCAD

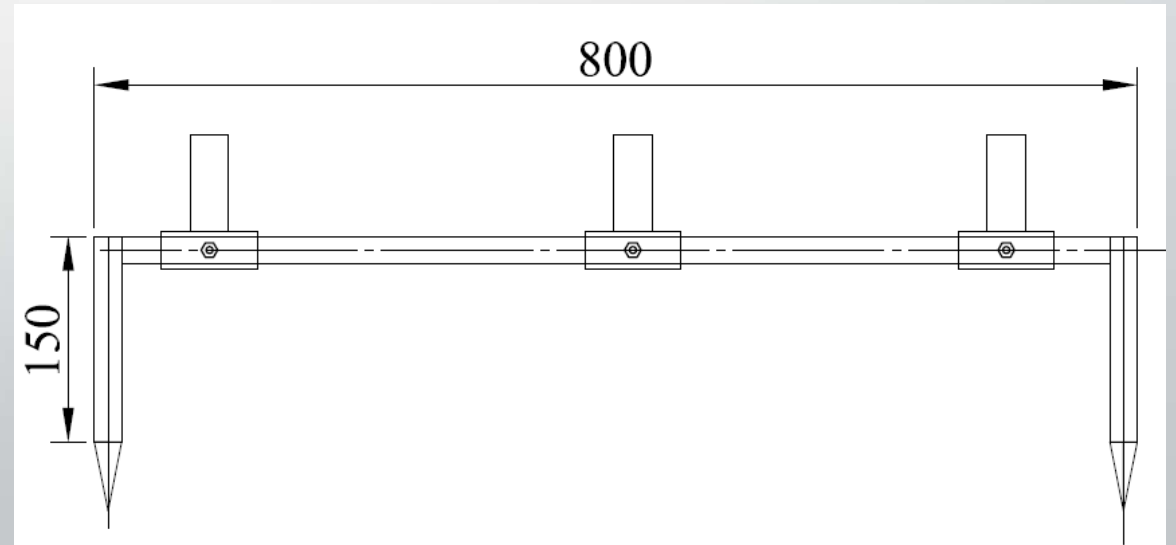
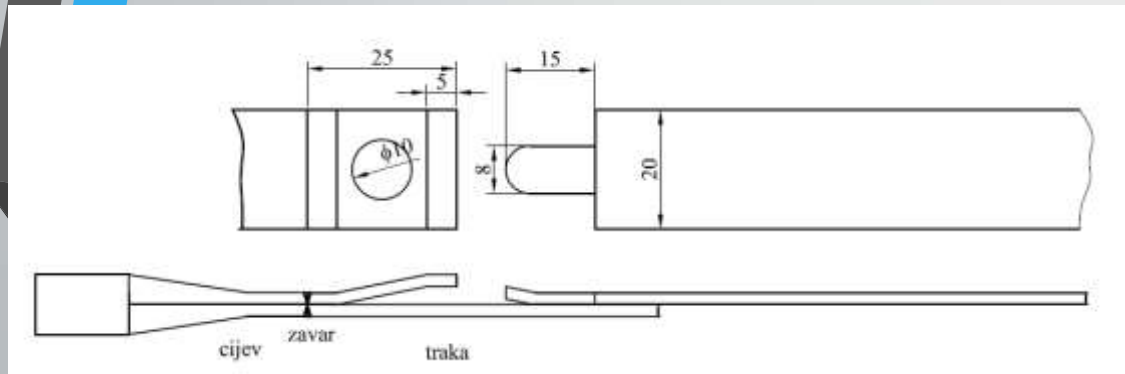
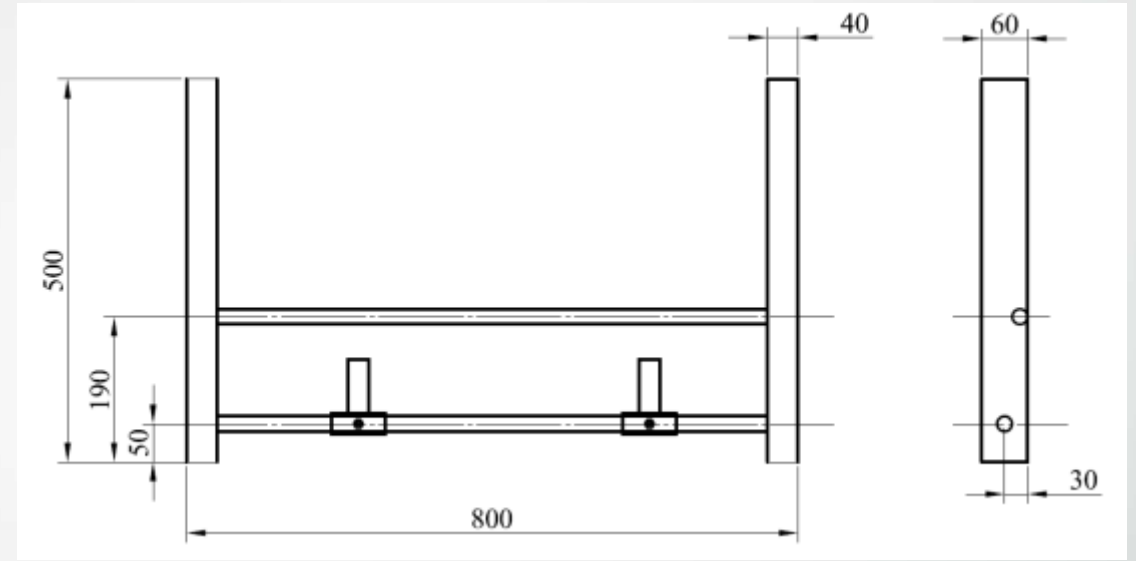
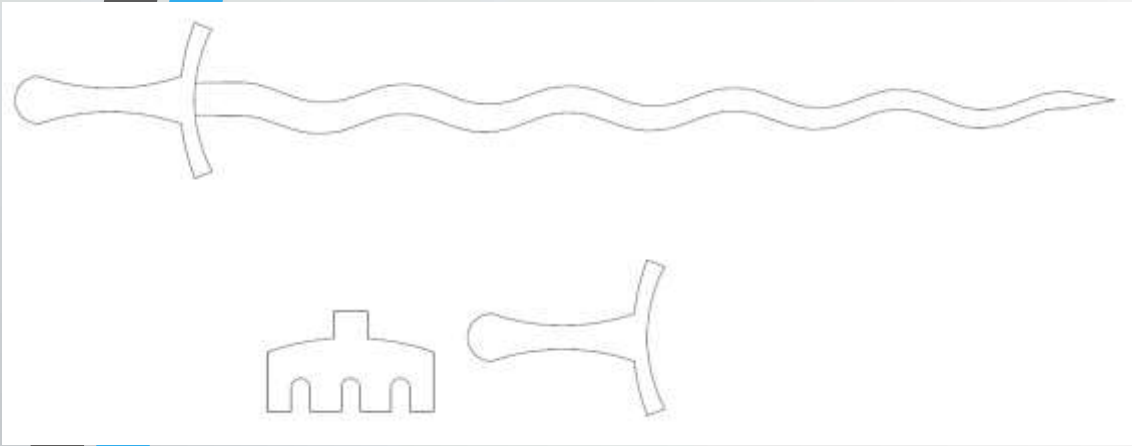

Prototype products



Prototype products



Testing a prototype GASTRO-forks



Testing a prototype GASTRO-forks



Making a series GASTRO-forks stainless steel



Making a series GASTRO-forks stainless steel



Making a series GASTRO-forks stainless steel

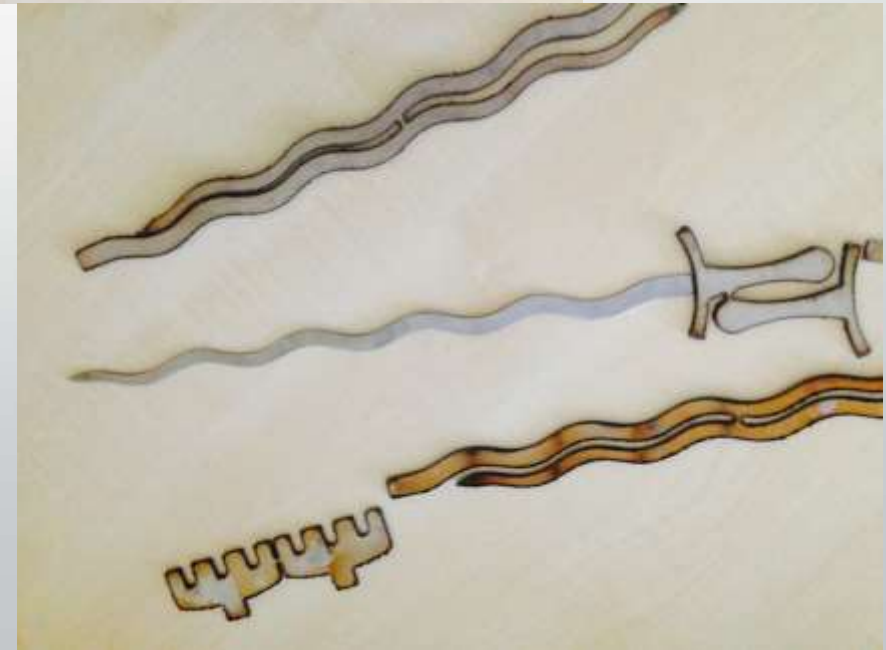

presentation of the product - Velika



presentation of the product - Velika

